

INSTALLATION

- 1 Take a 25NB Rigid PVC Riser pipe, longer than the height of the vessel and solvent cement the bottom distributor to one end of the pipe.
- 2 Insert this riser pipe into the vessel and cut the pipe from the top ensuring that the height of the pipe (with the distributor touching the bottom) is 42mm more than the top of the vessel.
- 3 Pour RESIN into the vessel. Cover the mouth of the riser pipe while doing this so that resin doesn't enter the pipe. Align the riser pipe so that it is in the centre of the vessel opening.
- 4 Screw on the top distributor to the bottom of the MPV.
- 5 Screw on the MPV to the vessel ensuring that the riser pipe goes through the top distributor into the MPV.

NOTE: You can also fill the RESIN in the vessel first and also fill some water in it. Then follow the procedure of cementing bottom distributor, cutting correct length of riser pipe, fixing top distributor to MPV and then pushing the riser pipe through the top distributor into the MPV. Now this MPV with attached riser pipe can be pushed into the vessel and screwed on the top.

- 6 Connect the suction filter assembly to the ejector suction nozzle after fitting a 3/4" valve on the suction elbow of the MPV.
- 7 Put the suction filter into the Brine tank ensuring that the suction filter always remain vertical. You can cut the supplied tubing to the correct length so that the tubing always remain taut and does not loop. Alternatively the suction filter can be inserted in a 3" PVC pipe (with slot at the bottom) which is clamped to the Brine tank.
- 8 Make the Inlet, Outlet and Drain connections.

OPERATION

- 1 Always press the handle down before turning the handle to the desired position viz. Service, Regeneration or Rinse.
- 2 If the line pressure is more, It is advisable to close the inlet valve before turning handle.
- 3 Ensure that minimum 2kg/cm² pressure is available for getting optimum ejector performance.
- 4 If there is a suction problem even at 2kg/cm² then the ejector may be clogged with dirt etc. For cleaning this, remove the ejector by unscrewing it from the MPV, clean and put back.

**INITIATIVE
ENGINEERING**
An ISO 9001-2008 Organization

Sr. No. 273, Near Vitthal Mandir, Bhatewara Nagar,
Hinjawadi, Pune - 411 057, Maharashtra (India)
Tel.:+91 20 2293 2122, +91 20 2293 2123
E-MAIL:info@initiativeengineering.com
www.initiativeengineering.com

MULTIPORT VALVE STM40FF

SPECIFICATIONS

- | | |
|--|---|
| 1. Inlet/Outlet/ Drain connections | : 1.5" BSP |
| 2. Valve Threading for Vessel Mounting | : 2.5" NPSM |
| 3. Flow Rate | : 6m ³ /hr @0.5kg/ cm ² |
| 4. Max. Operating Pressure | : 5kg/ cm ² |
| 5. Ejector Suction at 2kg/ cm ² | : 750Lph |
| 6. Ejector Ratio | : 1:1 |
| 7. Brine Line | : 3/4" BSP |

SCOPE OF SUPPLY

1. Multiport valve
2. Top and Bottom Distributor
3. O & M Manual

GENERAL ASSEMBLY

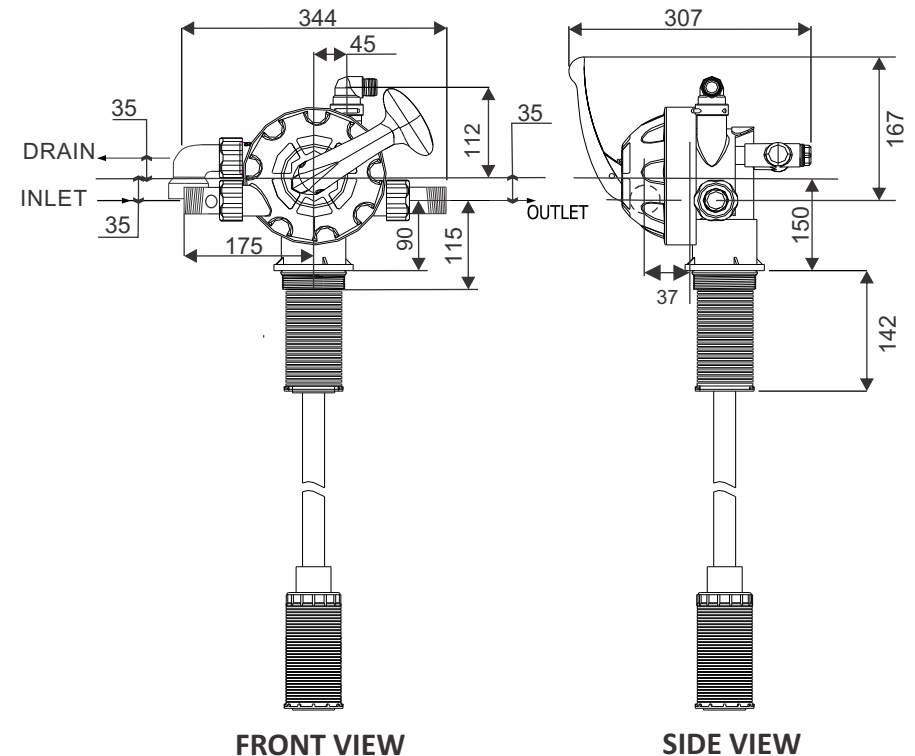

PARTS LIST

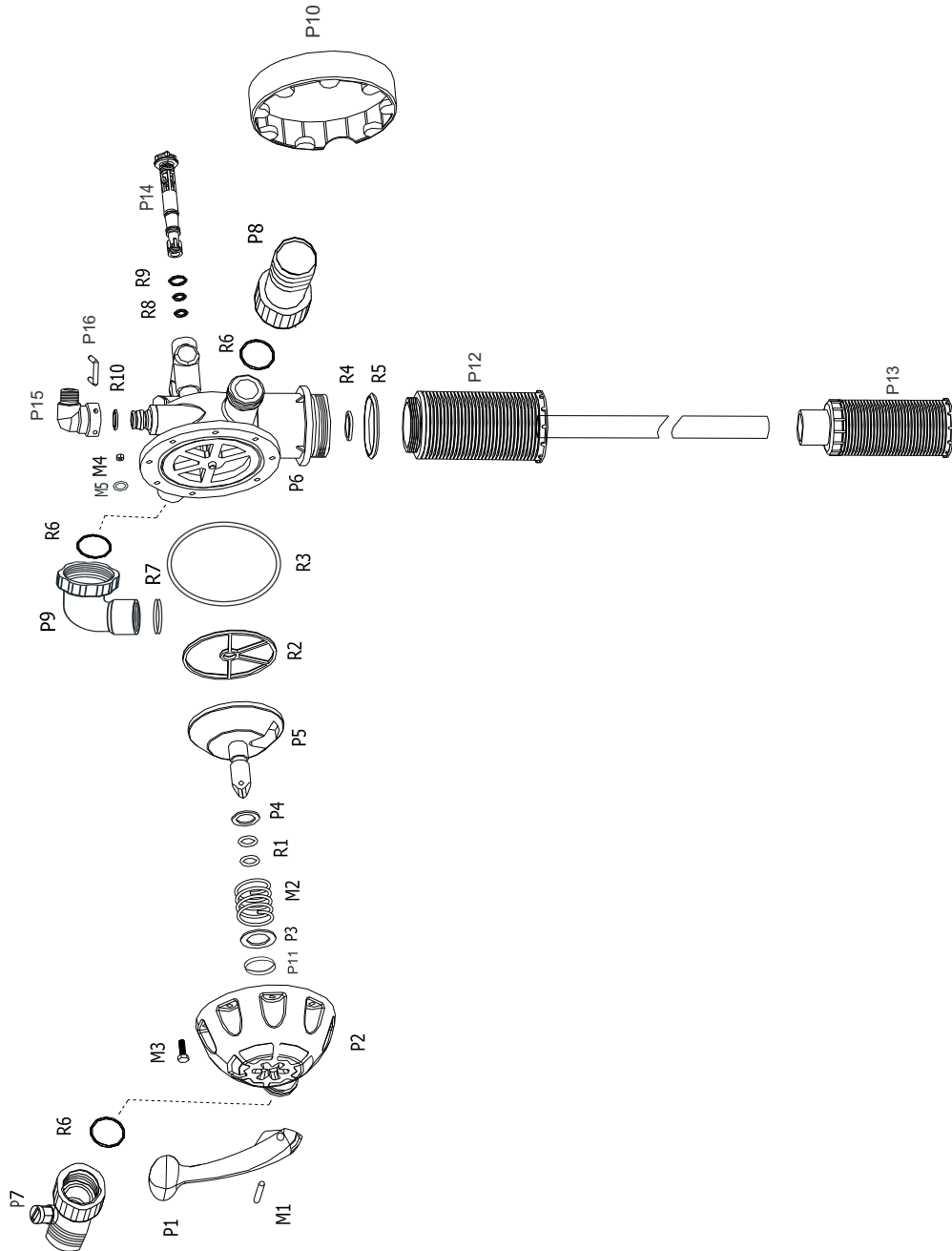

SR.NO.	DESCRIPTION	PART NO
1.	Handle	P1
2.	Upper Housing	P2
3.	Spring washer	P3
4.	Disc Washer	P4
5.	Disc	P5
6.	Lower Housing	P6
7.	Inlet Union Asembly	P7
8.	Outlet Union Asembly	P8
9.	Drain Elbow Assembly	P9
10.	Band	P10
11.	Upper Housing bush	P11
12.	Top Distributor	P12
13.	Bottom Distributor	P13
14.	Ejector	P14
15.	Suction Elbow	P15
16.	U Pin	P16
17.	Handle Pin (8mm)	M1
18.	Spring	M2
19.	Bolt (M6X28)	M3
20.	Nut (M6)	M4
21.	Split Washer (M6)	M5
22.	Disc 'O' ring (18.5X3.6)	R1
23.	Star washer	R2
24.	Lower Housing Flange 'O' Ring (139x4.70)	R3
25.	Riser Pipe Adaptor 'O' Ring (31.5X3.2)	R4
26.	Lower Housing 'O' Ring (65X4.5)	R5
27.	Union Assembly 'O' Ring (44X3)	R6
28.	Drain Elbow Assembly washer (38x45x2.5)	R7
29.	Ejector 'O' Ring (16X2.2)	R8
30.	Ejector Knob Oval Ring (21X28X2.5)	R9
31.	Suction Nozzle 'O' Ring (13.2X2.1)	R10