

INSTALLATION

1. Take a 20NB Rigid PVC Riser pipe, approximately the height of the vessel and solvent cement the bottom distributor to one end of the pipe.
2. Insert this Riser pipe into the vessel and cut the pipe from the top ensuring that the height of the pipe (with the distributor touching the bottom) is the same as the top of the vessel.
3. Pour gravel and then filter media into the vessel. Cover the mouth of the Riser pipe while doing this so that media doesn't enter the pipe. Align the Riser pipe so that it is in the center of the vessel opening.
4. Screw on the top distributor to the bottom of the MPV.
5. Screw on the MPV to the vessel ensuring that the riser pipe goes through the top distributor into the MPV.
6. Make the Inlet, Outlet and drain connections.

OPERATION

1. Always press the handle down before turning the handle to the Desired position viz. Service, Backwash or Rinse.
2. If the line pressure is more , It is advisable to close the Inlet Valve before turning handle.



**INITIATIVE
ENGINEERING**
An ISO 9001-2008 Organization

Sr. No. 273, Near Vitthal Mandir, Bhatewara Nagar,
Hinjawadi, Pune - 411 057, Maharashtra (India)
Tel.:+91 20 2293 2122, +91 20 2293 2123
E-MAIL:info@initiativeengineering.com
www.initiativeengineering.com

MULTIPORT VALVE F0225TF

SPECIFICATIONS

- | | |
|--|--|
| 1. Inlet/Outlet/Drain connections | : 1" BSP |
| 2. Valve threading for Vessel Mounting | : 2.5" NPSM |
| 3. Flow Rate | : 2m ³ /hr @0.35kg/ cm ² |
| 4. Max. Operating Pressure | : 5kg/ cm ² |

SCOPE OF SUPPLY

1. Multiport valve
2. Top and Bottom Distributors
3. O & M Manual

GENERAL ASSEMBLY

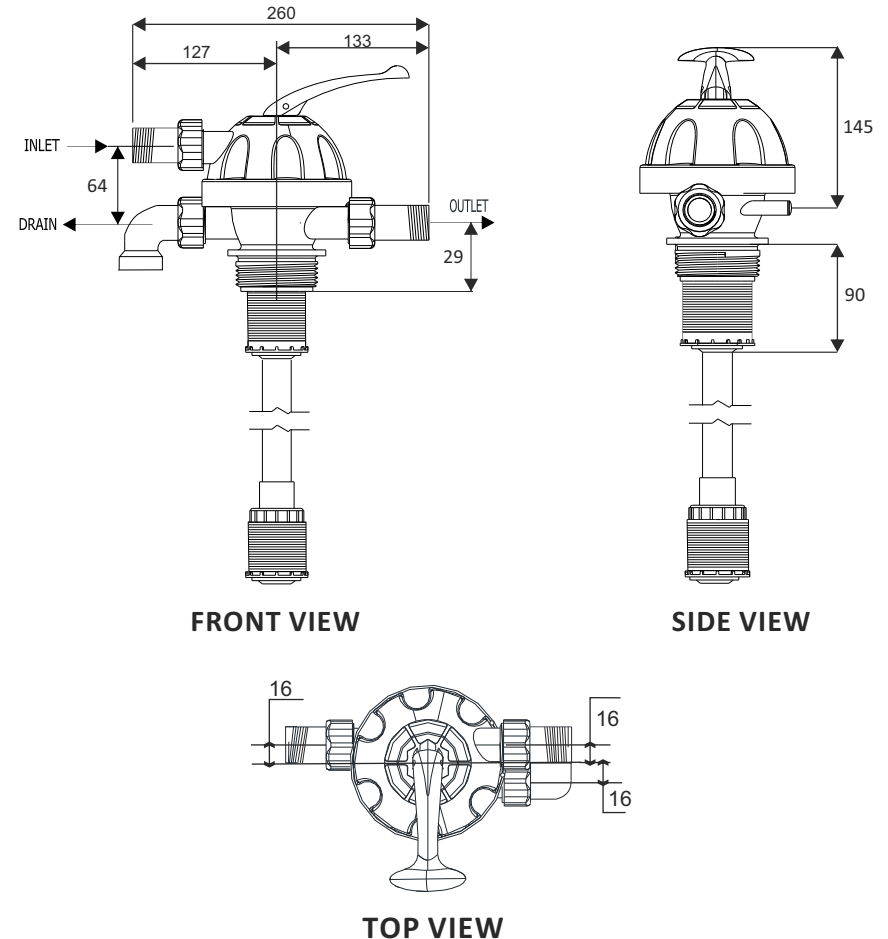

EXPLODED VIEW

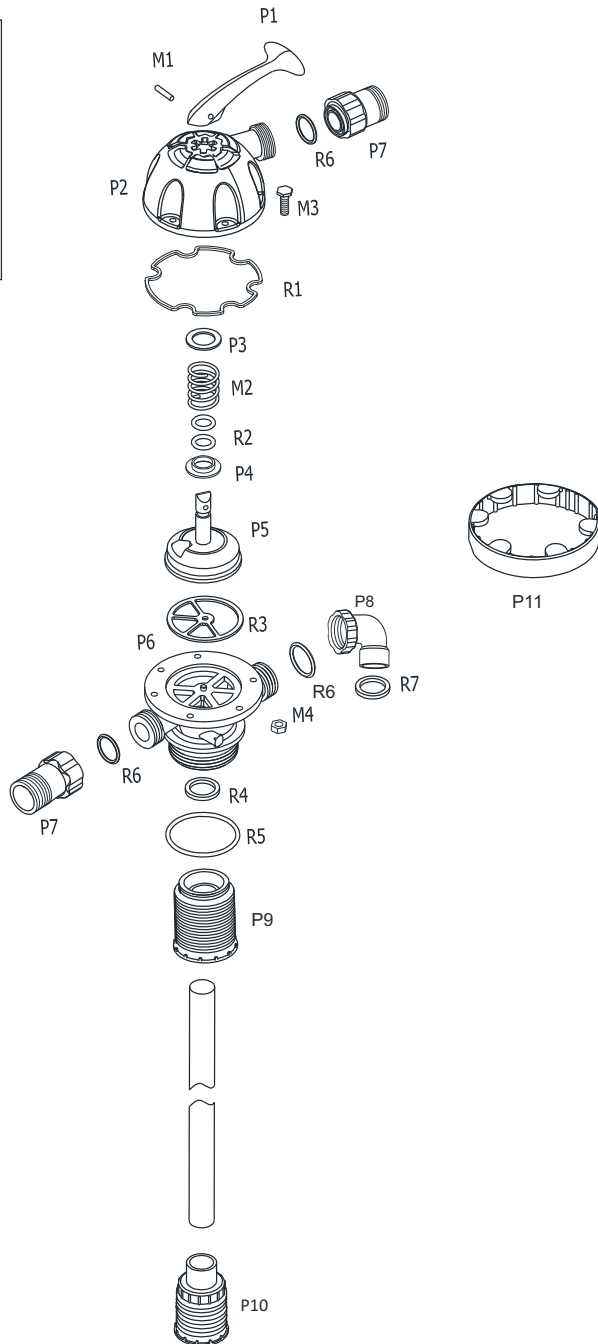
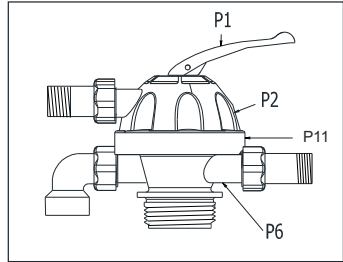

PARTS LIST

SR.NO.	DESCRIPTION	PART NO
1.	Handle	P1
2.	Upper Housing	P2
3.	Spring Washer	P3
4.	Disc Washer	P4
5.	Disc	P5
6.	Lower Housing	P6
7.	Union Assembly	P7
8.	Drain Elbow Assembly	P8
9.	Top Distributor	P9
10.	Bottom Distributor	P10
11.	Band	P11
12.	Handle Pin (5MM)	M1
13.	Spring	M2
14.	Bolt (M6X25)	M3
15.	Nut (M6)	M4
16.	Upper Housing Washer	R1
17.	Disc 'O' Ring (9.5X2.62)	R2
18.	Star Washer	R3
19.	Riser Pipe Adaptor 'O' Ring (24.5X2.8)	R4
20.	Lower Housing 'O' Ring (65X4.5)	R5
21.	Union Assembly 'O' Ring (26.5X3)	R6
22.	Drain Elbow Assembly washer (24x31x2.6)	R7